

# Jordan TEAM Together Grade 3 Semester 1



Activity Book

### *Adaptation Committee in Jordan*

Prof. Nayel Darweesh Al-Shara'h (Head)

Dr. Manal Fahed Aburumman (Coordinator)

Prof. Dina AbdulHameed Al-Jamal

Dr. Hamzah Ali Omari

Dr. Zeina Mohammad AlKaraki

**Publisher: The National Center for Curriculum Development and Evaluation**

**The National Center for Curriculum Development and Evaluation is pleased to have your feedback and comments on this book through the following contact details:**

 06-5376262 / 237

 06-5376266

 P.O.Box: 2088 Amman 11941

 @nccdjor

 feedback@nccd.gov.jo

 www.nccd.gov.jo

The Ministry of Education has decided to adopt this book for Jordanian schools in accordance with the approval of the Higher Council of the National Center for Curriculum Development and Evaluation in its meeting No. 3/2024 on 7/5/2024 and the approval of the Board of Education decision No. 42/2024 in its meeting No. 3/2024 on 26/6/2024 for the 2025/2026 academic year.

First edition (trial) © Pearson Education Limited and York Press Ltd. 2024

Second edition (revised and updated) © Pearson Education Limited and York Press Ltd. 2025

ISBN: 978-9923-41-912-0

The Hashemite Kingdom of Jordan  
Deposit number by the National Library Department  
(2025/3/1593)

**Primary indexing data for the book**

<b>Book title</b>	Jordan Team Together, Grade 3: Activity Book, Semester 1
<b>Prepared by / staff</b>	Jordan National Center for Curriculum Development
<b>Publication data</b>	Amman: National Center for Curriculum Development, 2025
<b>Classification number</b>	375.001
<b>Descriptors</b>	/Curriculum Development//Courses//Levels of Education/
<b>Edition data</b>	Second Edition, Revised and Updated

The author bears full legal responsibility for the content of their work, and this work does not express the opinion of the National Library Department.

The right of Lesley Koustaff and Susan Rivers to be identified as authors of this \*work has been asserted by them in accordance with the Royal Legislative Decree, 12 April 1/1996, which approves the consolidated text of the Law of Intellectual Property Rights.

The publishers would like to thank Sarah O'Connell for her contribution.

All rights reserved; no part of this publication may be reproduced, stored in a retrieval system, or transmitted in any form or by any means, electronic, mechanical, photocopying, recording, or otherwise without the prior written permission of the Publishers.

Printed 2024

Reprinted 2025 - 2026

\* The term "work" in this context refers to the original text (publication) before the adaptation to the Jordanian culture

# Jordan TEAM Together Grade 3 Semester 1



Activity Book

## Contents

Welcome Back to school .....	2	<b>Festivals</b>	
1 It's a happy day! .....	6	Months and seasons .....	40
2 Let's dress up! .....	14	Independence Day .....	41
3 The activity centre .....	22	<b>Picture dictionary</b> .....	42
4 I want to be a teacher! .....	30		
<b>Atomic's Learning Club</b>			
Language booster .....	38		



Pearson

Lesley Koustaff and Susan Rivers



Welcome

# Back to school

1 Look, read and write.

Polly

Tom

Laila

~~Sami~~

Bo

Atomic

\_\_\_\_\_

Sami

\_\_\_\_\_

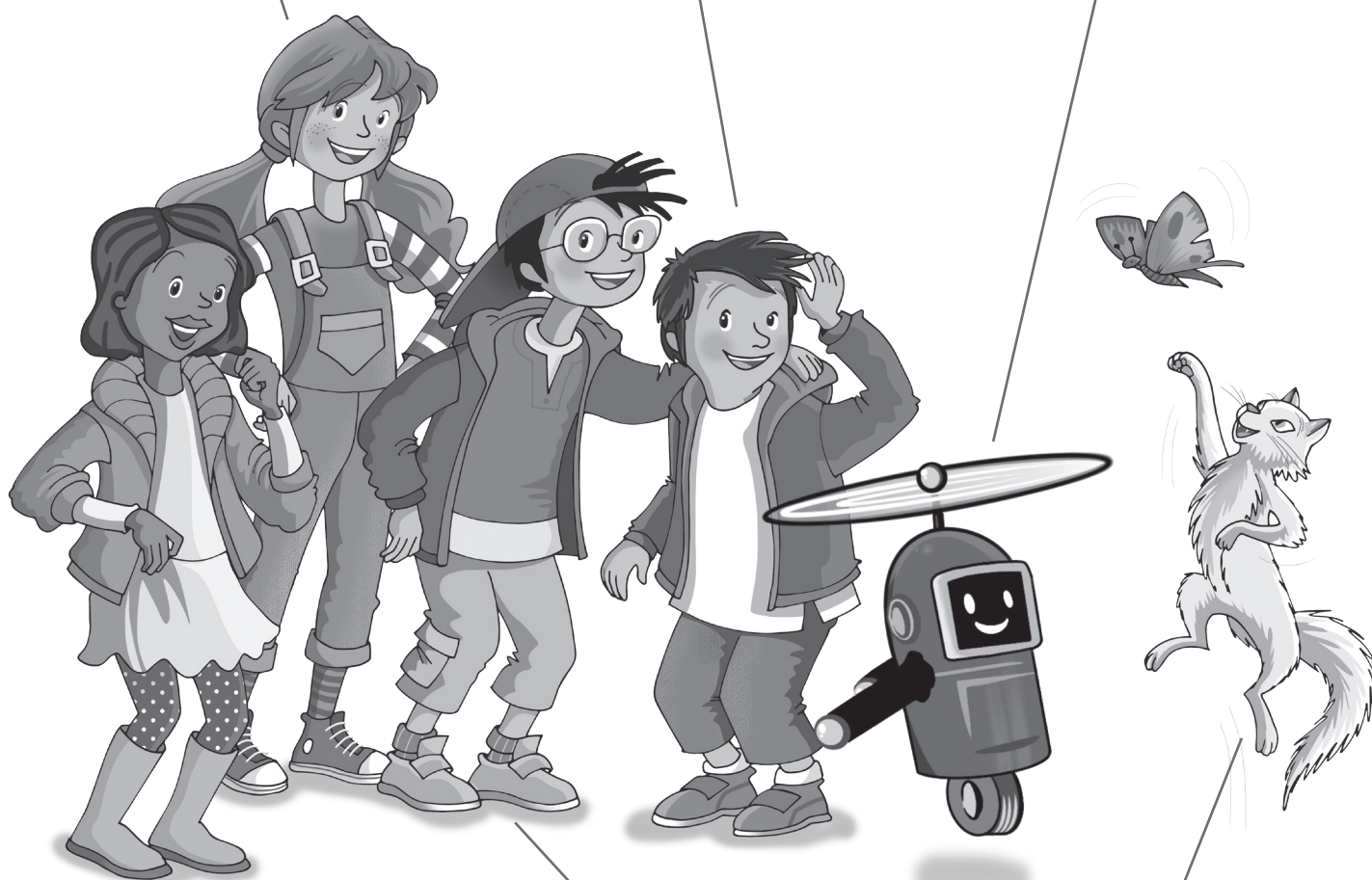

\_\_\_\_\_

\_\_\_\_\_

\_\_\_\_\_

2  Look and write. Then listen, sing and check.



p ~~d~~ x l t h



3  Listen and write.



1



A s m a

2



G \_ \_ \_ \_

3



N \_ \_ \_ \_

4



M \_ \_ \_ \_



1 Listen, circle and match.

1 **This is** **These are** a pen.

2 **These are** **Those are** desks.

3 **This is** **That is** a ball.

4 **These are** **That is** teddies.

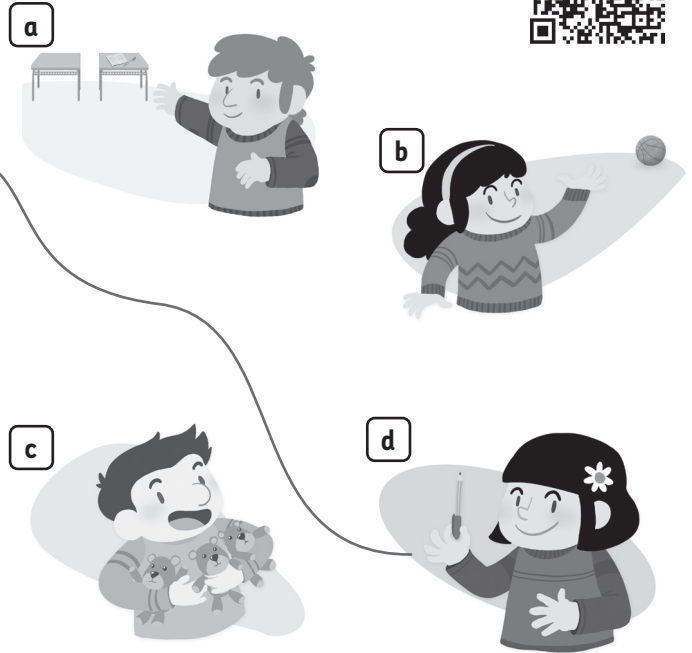

2 Look, read and write.

This is      That is      These are      Those are

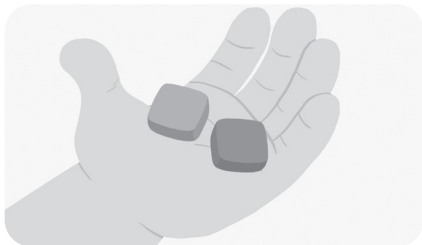

1 These are  
erasers.

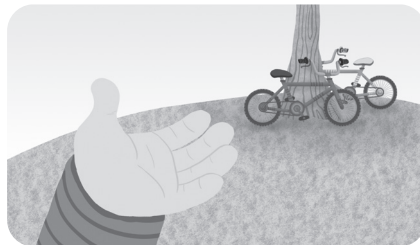

2 \_\_\_\_\_  
bikes.

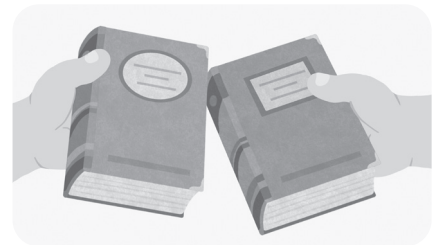

3 \_\_\_\_\_  
books.

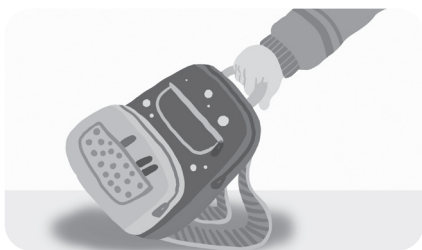

4 \_\_\_\_\_  
a bag.



5 \_\_\_\_\_  
kites.

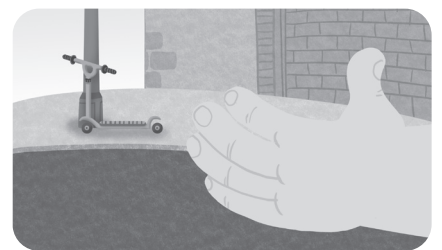

6 \_\_\_\_\_  
a scooter.



3 Listen and write. Then count and circle.

eighteen      fourteen      ~~twelve~~      sixteen

1 twelve

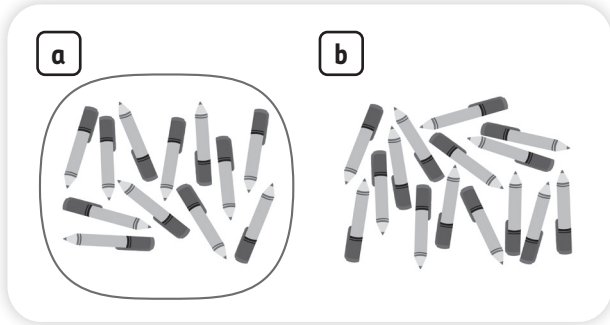

2 \_\_\_\_\_

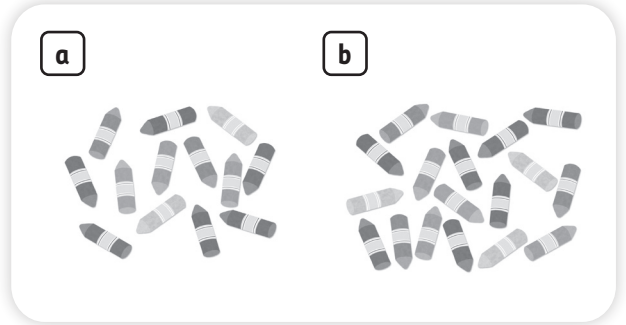

3 \_\_\_\_\_

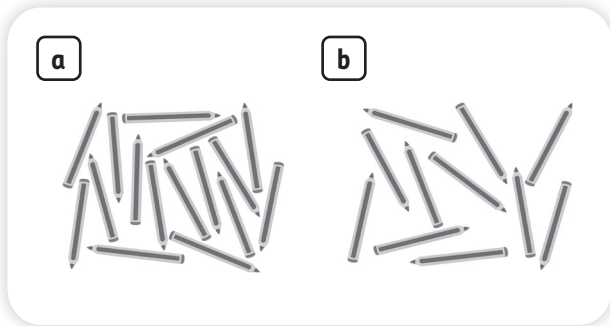

4 \_\_\_\_\_

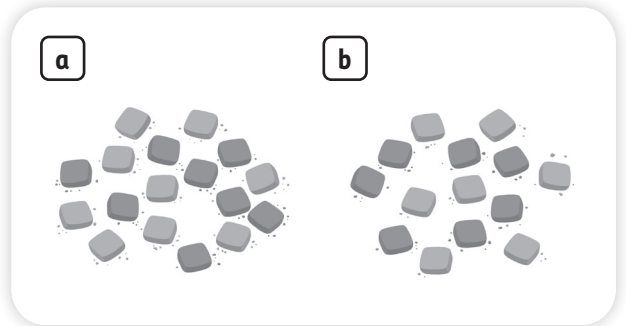

4 Count and write.

thirteen      seventeen      fifteen      ~~twenty~~

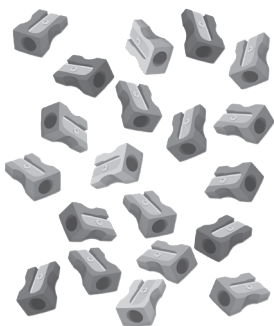

1 twenty      2 \_\_\_\_\_

3 \_\_\_\_\_

4 \_\_\_\_\_

# 1

## It's a happy day!

1  Look at Pupil's Book page 8. Read and answer.

1 Who's got water? \_\_\_\_\_

2 Where's Atomic? \_\_\_\_\_

3 What colour is the slide? \_\_\_\_\_

2 Look, read and write.

get up    have breakfast    go home    do homework  
have dinner    ~~go to bed~~    play with my friends  
go to school    have lunch    have art lessons



\_\_\_\_\_

*go to bed*

\_\_\_\_\_

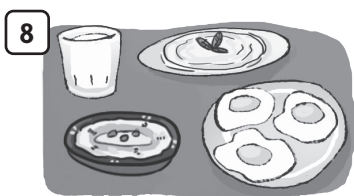
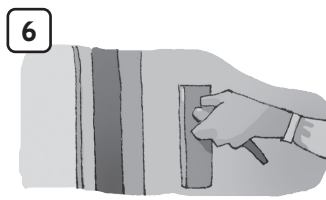
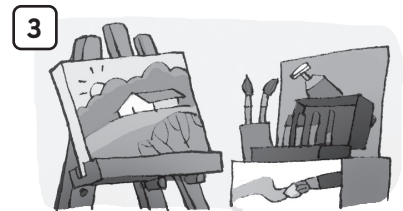

3 Follow and circle.

1 We I



play don't play  
baseball.

2 I We



have don't have  
lunch.

3 We I

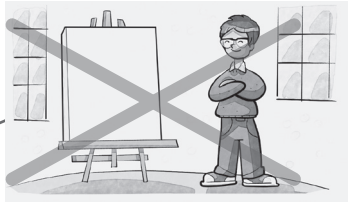

have don't have  
art lessons.

4 We I



go don't go  
to school.

4 Order and write.

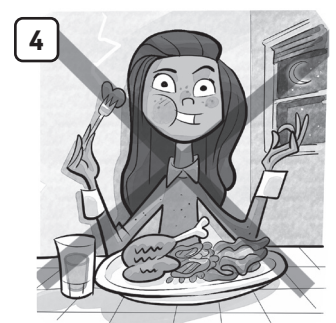
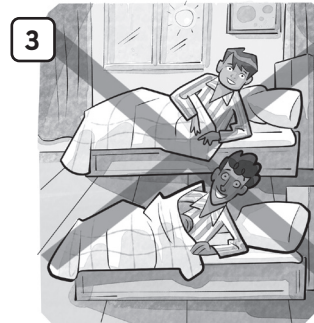
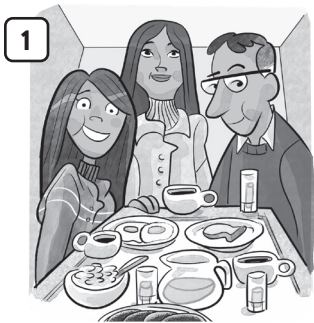

1 have / breakfast / We

We have breakfast.

2 go / I / home

\_\_\_\_\_

3 don't / We / up / get

\_\_\_\_\_

4 have / don't / dinner / I

\_\_\_\_\_

1 After you read Remember the story. Reorder the story.

Laila has paint brushes.

1

They paint Bo.

\_\_\_\_\_

Sami and Tom have tennis lessons in the morning.

\_\_\_\_\_

Polly, Laila, Tom and Sami have art lessons.

\_\_\_\_\_

Blue and yellow make green.

\_\_\_\_\_

Atomic is on the table.

\_\_\_\_\_

2 Values Look and tick (✓) or cross (X).



3 Look and colour.

Bo is colourful!



1 Look and circle.

1 in the afternoon

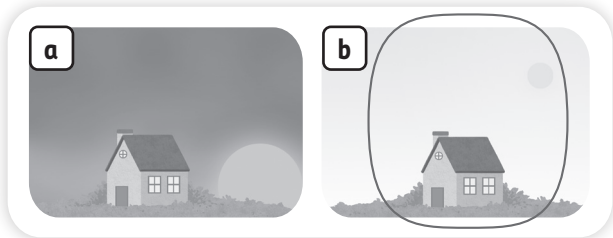

2 in the morning

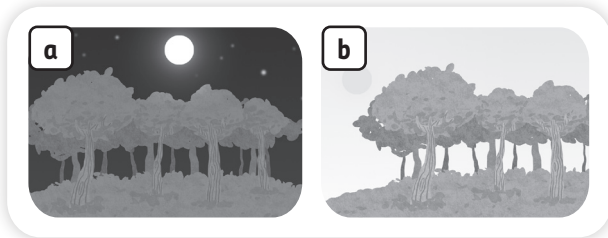

3 at night

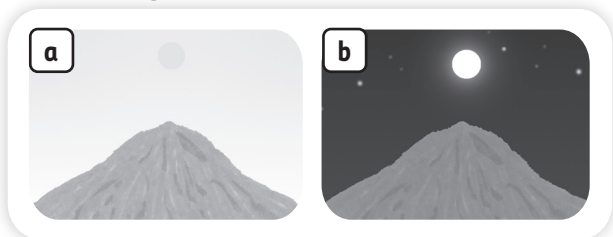

4 in the evening

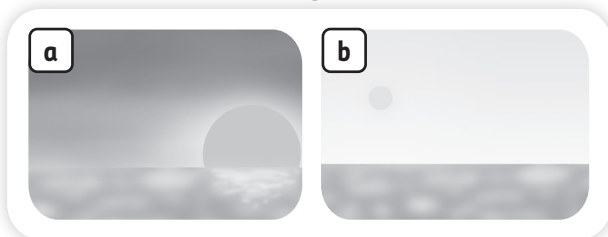

2 Look, read and answer.

in the morning      in the afternoon  
in the evening      ~~at night~~



1 When do you go to bed?

We go to bed at night.



2 When do you have art lessons?

\_\_\_\_\_



3 When do you go to school?

\_\_\_\_\_



4 When do you do homework?

\_\_\_\_\_

### 1 Read and answer.

#### Omar and Raed's day



Dear Salah,  
 We're Omar and Raed. We're brothers.  
 This is our day.  
 First, we have art lessons in the morning.  
 Then we have lunch in the afternoon.  
 We don't play in the afternoon.  
 We do homework.  
 Then we have dinner in the evening.  
 We play in the evening, too.  
 After that, we go to bed at night.  
 From Omar and Raed

1 When do you play?

We play in the evening.

2 When do you have art lessons?

\_\_\_\_\_

3 When do you go to bed?

\_\_\_\_\_

4 When do you do homework?

\_\_\_\_\_

### 2 Write, draw and share.

Dear \_\_\_\_\_,

This is my day. First, I \_\_\_\_\_ in

the \_\_\_\_\_. Then I \_\_\_\_\_

in the \_\_\_\_\_. Then I \_\_\_\_\_

in the \_\_\_\_\_. After that,

I \_\_\_\_\_ at \_\_\_\_\_.

From \_\_\_\_\_





## 1 Look, read and write.

cereal pickles porridge soup tea toast

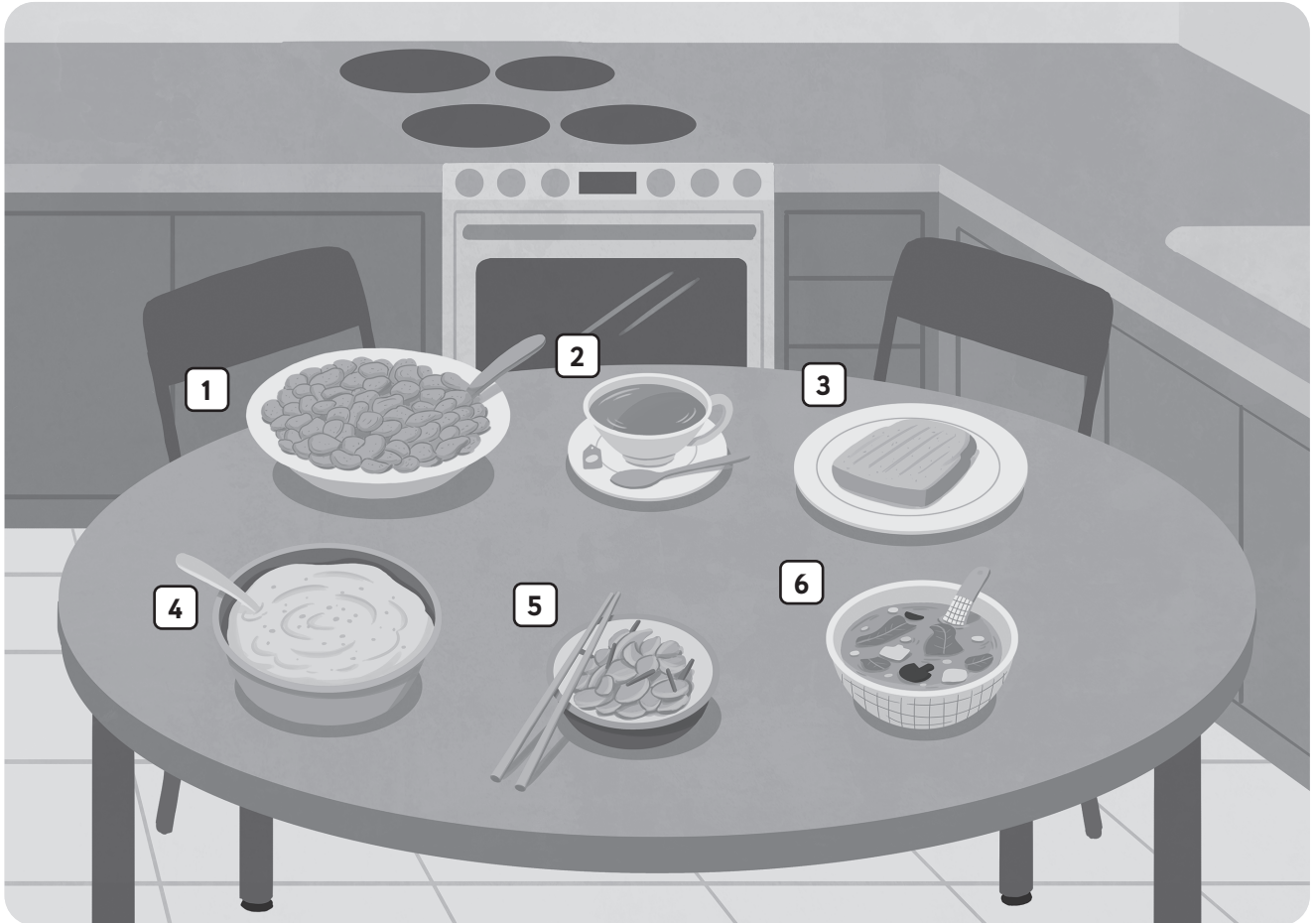

1 \_\_\_\_\_ cereal \_\_\_\_\_

4 \_\_\_\_\_

2 \_\_\_\_\_

5 \_\_\_\_\_

3 \_\_\_\_\_

6 \_\_\_\_\_

## 2 After you read Read and circle.

1 *Mfarrakeh* is a dish of potatoes and **eggs** **fish**.

2 People in **Japan** **South Africa** have corn porridge for breakfast.

3 Some people in **Japan** **the UK** eat a big breakfast.

4 In Japan, some people have **fish** **toast** for breakfast.



1 Listen and write.

seven    dinner    ~~time~~    no



Phonics

Lesson 10

1 Look and say. Then choose and circle.

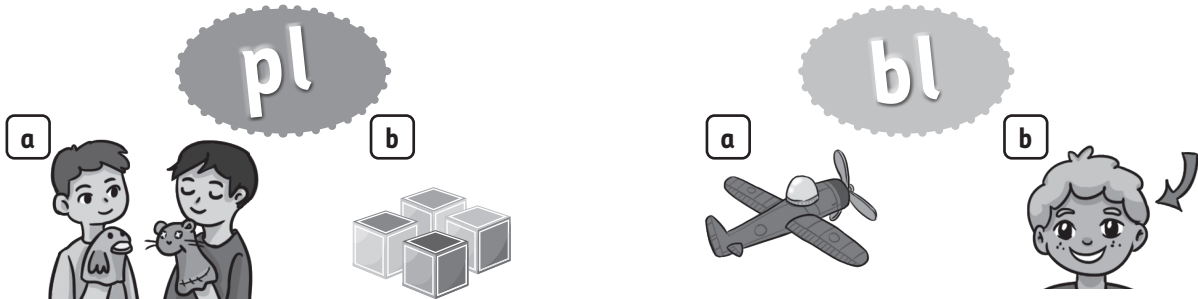

2 Are the sounds the same? Listen and tick (✓) or cross (X).



- 1     2     3     4     5     6

1 Look, read and number.

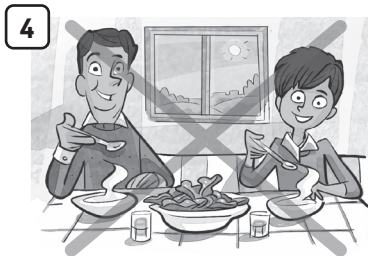
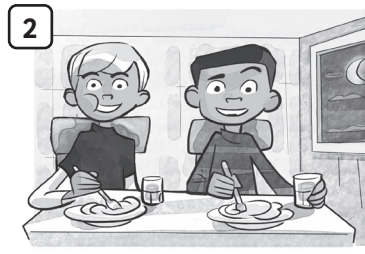

a We don't have lunch.

b I don't have art lessons.

c We get up.

d We do homework.

e I have breakfast.

f We have dinner.

2 Look, read and answer.

in the morning      in the afternoon  
in the evening      ~~at night~~



1 When do you go to bed?

We go to bed at night.

2 When do you go to school?

\_\_\_\_\_

3 When do you play?

\_\_\_\_\_

4 When do you go home?

\_\_\_\_\_

# 2

## Let's dress up!

1  Look at Pupil's Book page 16. Read and answer.

1 Who's wearing blue shoes? \_\_\_\_\_

2 How many socks can you see? \_\_\_\_\_

3 What colour is Laila's dress? \_\_\_\_\_

2  Listen, circle and write.



~~socks~~ scarf trainers sandals hat  
jeans dress shirt pyjamas

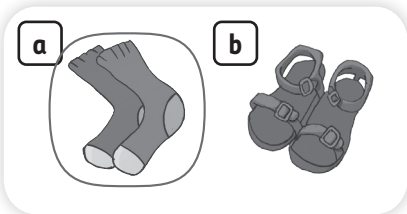

1 socks

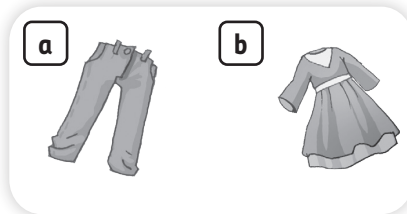

2 \_\_\_\_\_

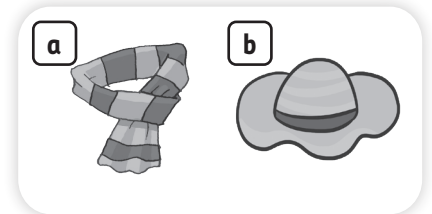

3 \_\_\_\_\_

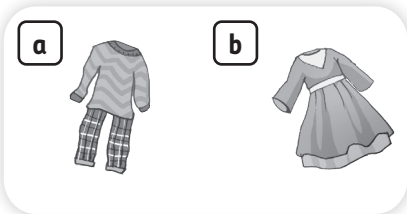

4 \_\_\_\_\_

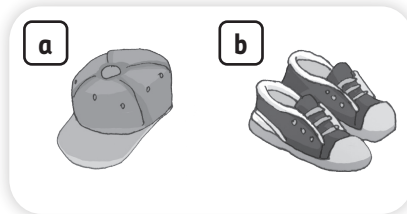

5 \_\_\_\_\_

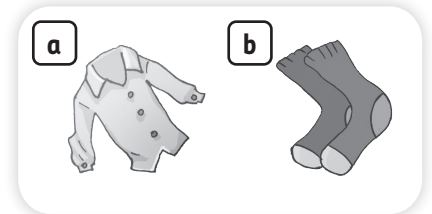

6 \_\_\_\_\_



7 \_\_\_\_\_

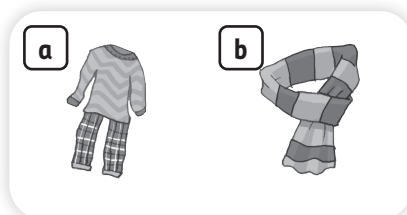

8 \_\_\_\_\_

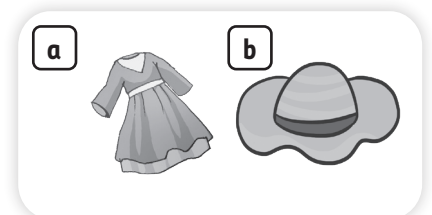

9 \_\_\_\_\_

3 Look, read and match. Then complete the sentences.

a

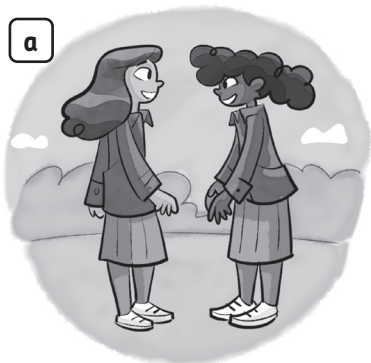

b

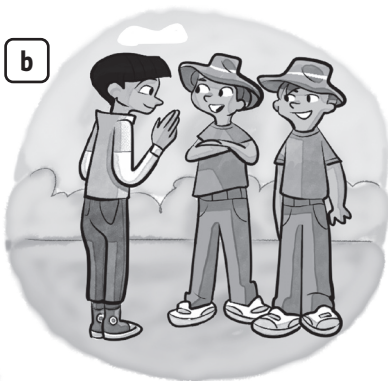

c



d

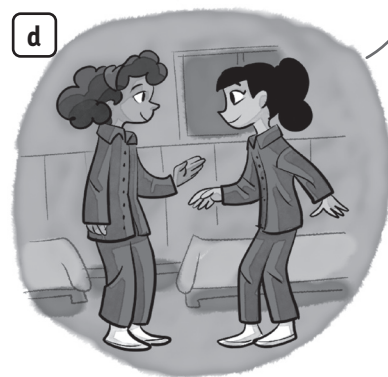

- 1 They're wearing pyjamas.
- 2 You're wearing hats, \_\_\_\_\_, jeans and trainers.
- 3 We're wearing T-shirts, shorts, socks and \_\_\_\_\_.
- 4 They're wearing shirts, \_\_\_\_\_ and trainers.

4 Look, read and write.

They're    You're  
              We're

trainers    ~~dresses~~    scarves  
              baseball caps

1 We're wearing dresses.

2 \_\_\_\_\_ wearing \_\_\_\_\_.

3 \_\_\_\_\_ wearing \_\_\_\_\_.

4 \_\_\_\_\_ wearing \_\_\_\_\_.

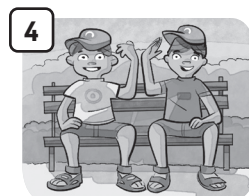

1 After you read Remember the story. Read and match.

- |   |                                     |   |                           |
|---|-------------------------------------|---|---------------------------|
| 1 | When is dress-up day?               | a | They're orange and green. |
| 2 | What colour is Laila's dress?       | b | It's at 3 o'clock.        |
| 3 | Are the jeans and shirts too small? | c | Yes, they are.            |
| 4 | Are Sami and Tom wearing scarves?   | d | It's blue.                |
| 5 | What colour are Tom's pyjamas?      | e | No, they aren't.          |

2  Values Look and write Yes or No.



\_\_\_\_\_

3  Look and colour.

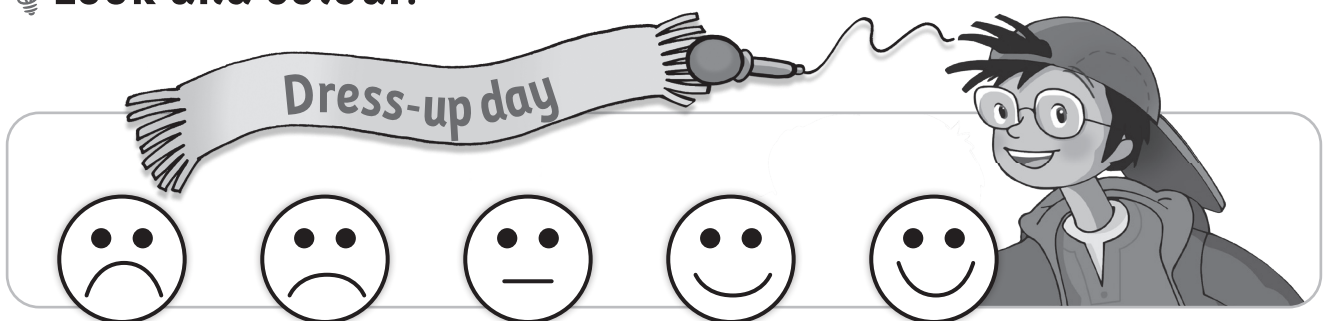

1 Look, read and write.

~~backpack~~ phone keys computer  
handbag glasses

1 b a c k p a c k

→ Across

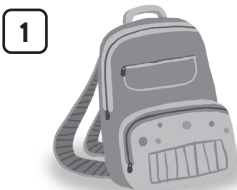

↓ Down

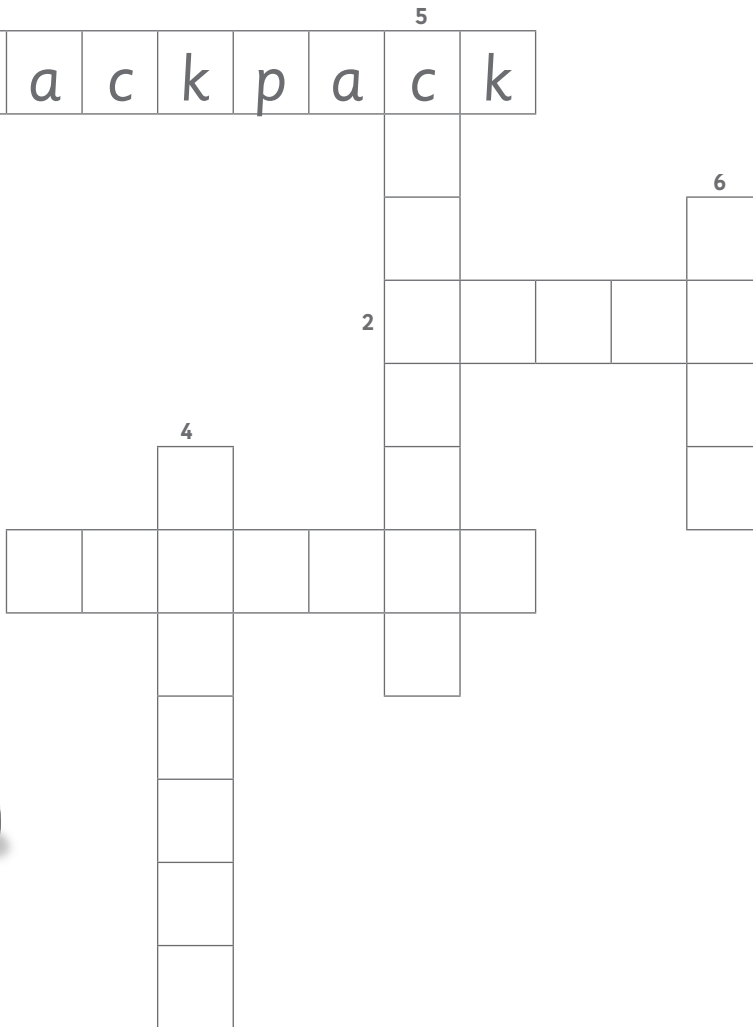

2 Match and colour.

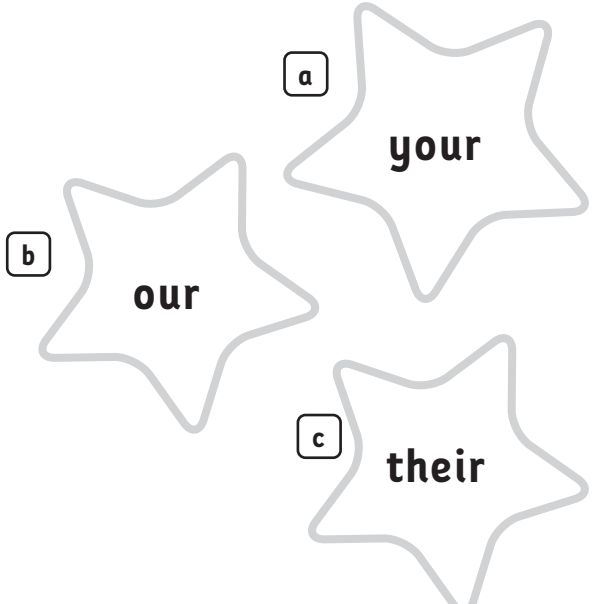
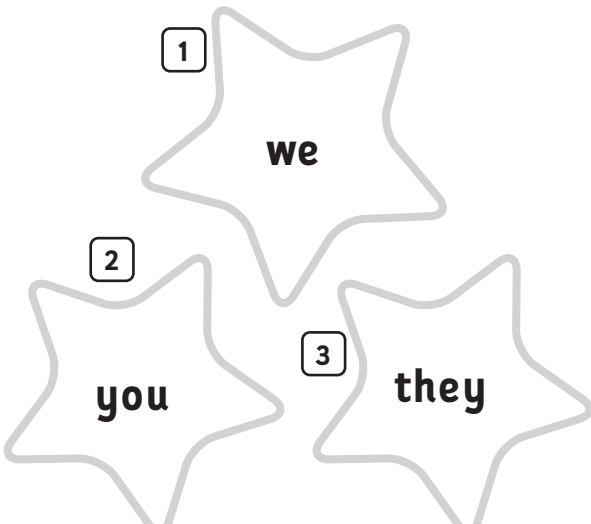

1 Read and look. Write Yes or No.

It's Tea Time!

We're having a tea gathering today. I'm in the garden with my family. It's hot and sunny. We're wearing hats. Our hats are big. Look! My mum and my sister are wearing dresses. Their dresses are red. My dad is wearing shorts and a shirt. His shorts are orange and his shirt is blue. You can see the cake, the tea cups and the sandwiches. Tea time is fun!

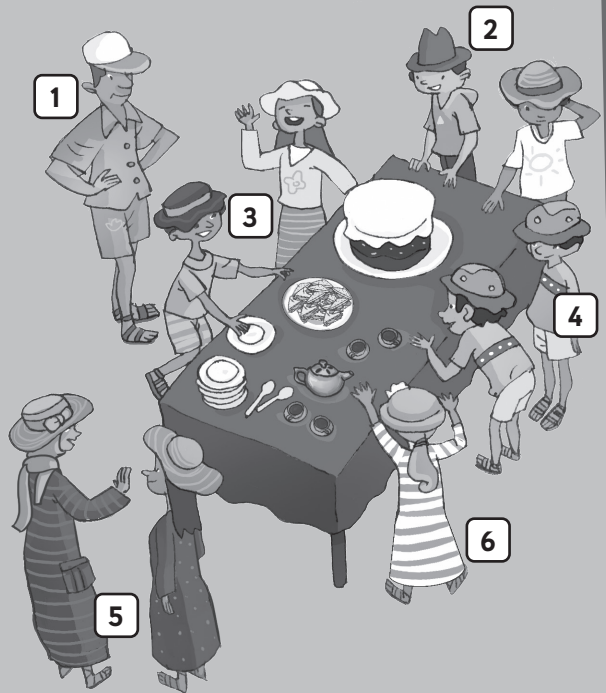

- 1 He's wearing a baseball cap. Yes
- 2 They're wearing hats. \_\_\_\_\_
- 3 His shorts and shirt are orange. \_\_\_\_\_
- 4 They're wearing socks. \_\_\_\_\_
- 5 Their dresses are red. \_\_\_\_\_
- 6 She's wearing blue jeans. \_\_\_\_\_

2 Write, draw and share.

Dear Grandma,  
 This is me at the dress-up day!  
 I'm wearing a \_\_\_\_\_  
 and \_\_\_\_\_.  
 My \_\_\_\_\_  
 is \_\_\_\_\_ and \_\_\_\_\_.  
 My \_\_\_\_\_  
 are \_\_\_\_\_ and \_\_\_\_\_.



1 Look, read and circle.



float parade



hat mask



kimono shirt



skirt kilt

2 After you read Read and write.

kilts Japan ~~parades~~ ride wear

- 1 They have parades in Switzerland.
- 2 People \_\_\_\_\_ fancy shirts.
- 3 Some people \_\_\_\_\_ on floats.
- 4 In \_\_\_\_\_, some people wear kimonos.
- 5 They're wearing \_\_\_\_\_ in this photo.





1 2.15 Listen and circle.



Excuse Help me.  
Yes, do can I help you?  
How much is this backpack handbag?  
It's 12 JD 20 JD.  
Here Have you are.  
Thank Please you.



Phonics

Lesson 10

1 2.19 Listen and write *tr*, *dr* or *br*.



1



\_\_\_ush

2



\_\_\_ess

3



\_\_\_ead

4

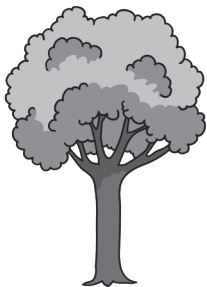

\_\_\_ee

5



\_\_\_ainers

6

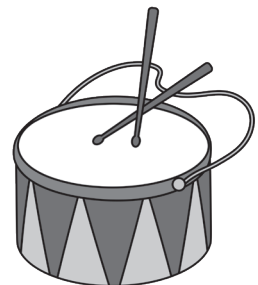

\_\_\_um

1 Look, read and circle. Then colour.

1

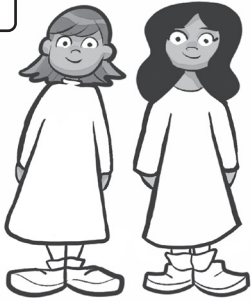

2



3



4



1 **We're** You're They're  
wearing a green dress, blue  
socks and black trainers.

2 **We're** You're They're  
wearing grey jeans, a yellow  
scarf and a brown hat.

3 **We're** You're They're  
wearing red pyjamas.

4 **We're** You're They're  
wearing purple sandals and  
orange baseball caps.

2 Order, write and colour.

1 glasses / Their / blue / are  
Their glasses are blue.

1

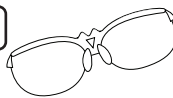

2

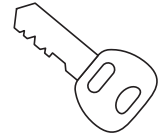

2 yellow / Their / keys / are



3 are / backpacks / Our / green

3



4

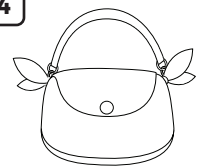

4 red / handbag / Your / is

5 computer / grey / is / Our

5

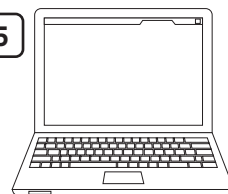

# 3

## The activity centre

1  Look at Pupil's Book page 24. Read and answer.

1 Who's wearing red trainers? \_\_\_\_\_

2 Who's wearing a dress? \_\_\_\_\_

3 How many baseball caps can you see? \_\_\_\_\_

2 Look, read and circle.



play table tennis  
play video games

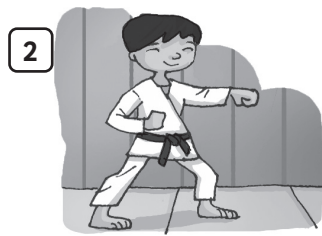

do karate  
play tennis



skateboard  
play badminton



watch TV  
roller skate



do karate  
skateboard



watch TV  
read books



play basketball  
play tennis

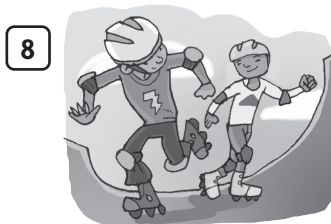

roller skate  
skateboard

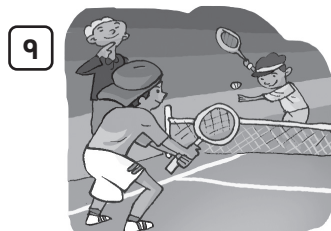

play tennis  
skateboard



watch TV  
play video games

3 Look, read and match.

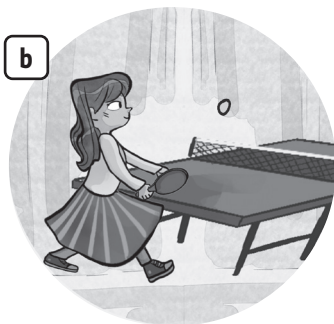

- 1 He plays basketball.
- 2 He doesn't do karate.
- 3 He doesn't watch TV.
- 4 She plays table tennis.

4  Listen, write and number.



~~doesn't skateboard~~      doesn't play tennis  
 reads books      plays basketball

1 He doesn't skateboard.

2 He \_\_\_\_\_.

3 He \_\_\_\_\_.

4 She \_\_\_\_\_.

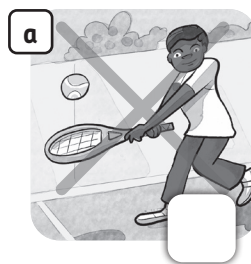

1

1 After you read Remember the story. Read and circle.



- 1 Laila roller skates doesn't roller skate at 9 o'clock.
- 2 Laila skateboards doesn't skateboard at 10 o'clock.
- 3 Bo can can't play table tennis.
- 4 Laila plays doesn't play tennis at 11 o'clock.
- 5 Atomic sees doesn't see the fish on TV.
- 6 The children have don't have lunch under a tree.

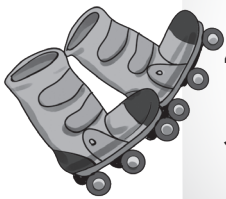

2 Values Look and tick (✓) or cross (X).



3 Look and colour.

Where's Laila?

1 Look, read and write.

~~Sunday~~

the weekend

Tuesday

Saturday

1

6  
Saturday

7  
Sunday

8  
Monday

2

20  
Thursday

21  
Friday

22

3

3  
Monday

4

5  
Wednesday

4

14  
Friday

+  
15  
Saturday

=

2 Look, read and answer.

1 Tuesday

2 Wednesday

3 Weekend

4 Sunday



Yes

No

does

doesn't

1 Does she play table tennis on Tuesday?

Yes, she does.

2 Does he roller skate on Wednesday?

\_\_\_\_\_, he \_\_\_\_\_.

3 Does he play tennis at the weekend?

\_\_\_\_\_, he \_\_\_\_\_.

4 Does he play video games on Sunday?

\_\_\_\_\_, he \_\_\_\_\_.

1 Read and circle.

**Laith and Maher's week**

Laith and Maher do a lot of things!  
 Laith plays tennis on Monday,  
 but he doesn't play basketball.  
 He plays basketball at the weekend.  
 Maher skateboards on Tuesday,  
 but he doesn't roller skate.  
 He roller skates on Thursday.

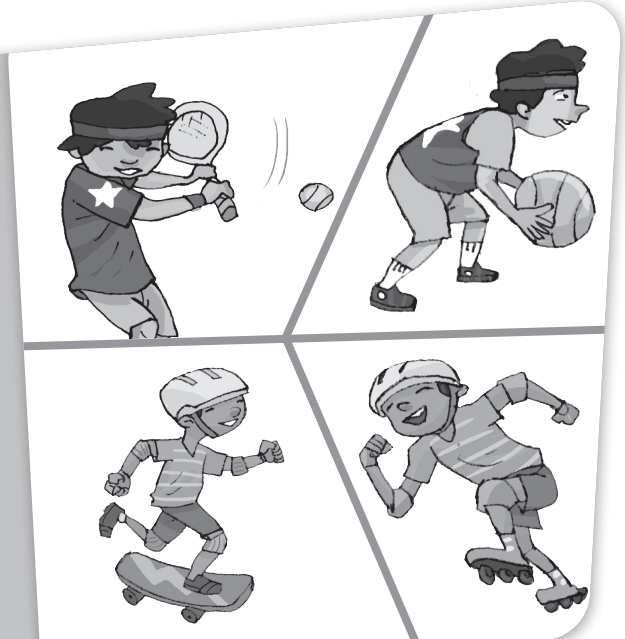

1 Does Laith play tennis on Monday?

Yes, he does.  No, he doesn't.

2 Does Laith play basketball at the weekend?

Yes, he does.  No, he doesn't.

3 Does Maher roller skate on Tuesday?

Yes, he does.  No, he doesn't.

4 Does Maher skateboard on Tuesday?

Yes, he does.  No, he doesn't.

2 Write, circle and draw. Then share.

Dear Uncle Abbas,  
 This is what I do every week.

I \_\_\_\_\_  
 on at \_\_\_\_\_.  
 I don't \_\_\_\_\_,  
 but I \_\_\_\_\_.  
 I play \_\_\_\_\_,  
 but I don't \_\_\_\_\_.

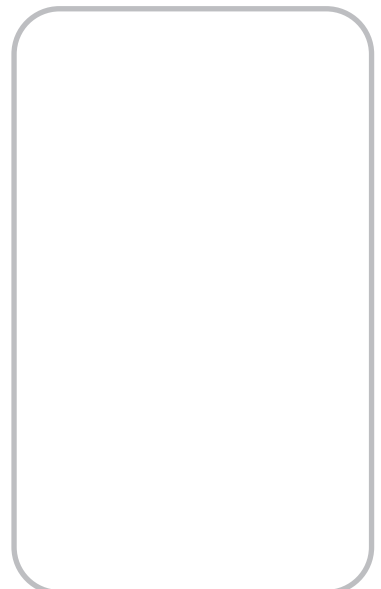

1 Look, read and tick (✓).

1 throw

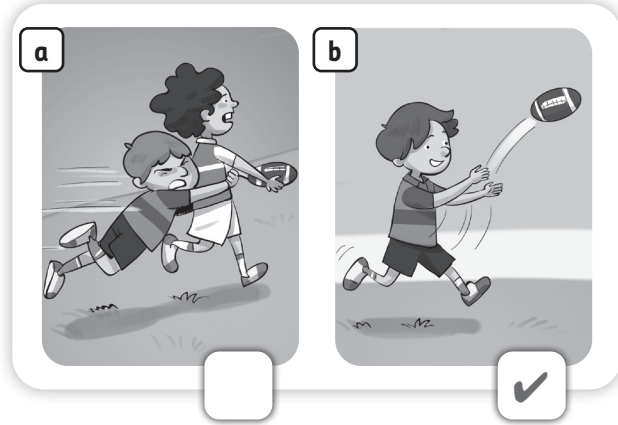

2 kick

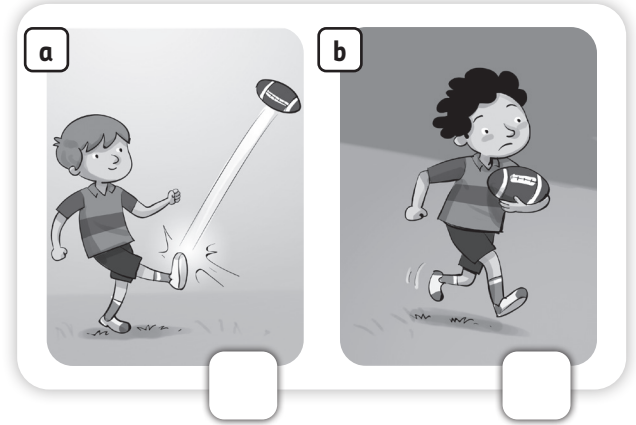

3 team

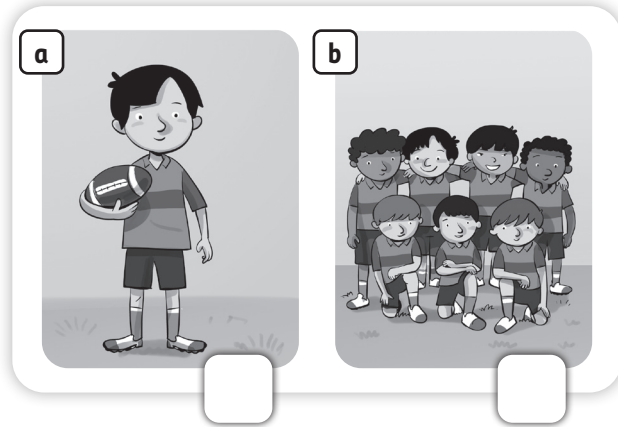

4 catch

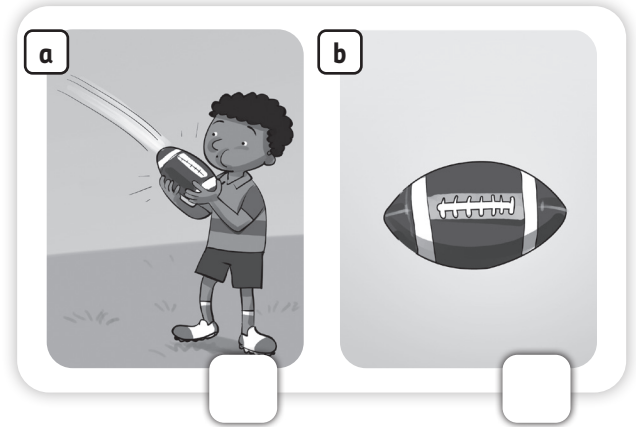

2 After you read Read and correct the words in bold.

kick    fifteen    ~~rugby~~    throw

1 A lot of boys in the UK play **basketball**.

rugby

2 A rugby team has got **twelve** players.

\_\_\_\_\_

3 A player can **catch** the ball to another player.

\_\_\_\_\_

4 Players **throw** the ball over the goal post.

\_\_\_\_\_



1 Listen and match.

1 What do you

2 I like

3 I don't like playing football, but I love

4 Me, too! Let's play

a doing karate.

b now.

c like doing?

d playing basketball.

Phonics

Lesson 10

1 Which word begins with a different sound? Listen and tick (✓).



1

a b c

2

a b c

3

a b c

4

a b c

2 Listen and write *sw*, *st* or *sk*.



1 \_\_\_ateboard    2 \_\_\_ing    3 \_\_\_irt

4 \_\_\_ar    5 \_\_\_im

**1 Look, read and write.**

roller skate  
skateboard

do karate  
read books

➔ **Across**

1

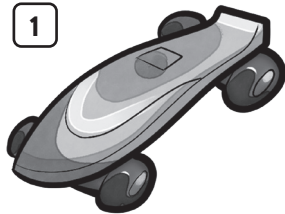

1 s k a t e b o a r d

↓ **Down**

2

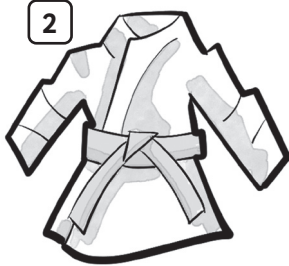

3



4



**2 Look, read and number.**

- 1 She watches TV.
- 2 She doesn't play tennis.
- 3 Does she read?  
Yes, she does.
- 4 Does he play basketball?  
No, he doesn't.

a



b

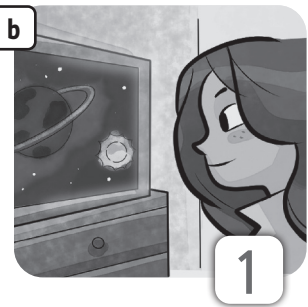

1

c

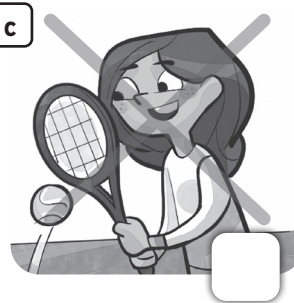

d

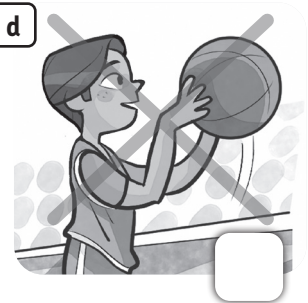

1

# 4

## I want to be a teacher!

1  Look at Pupil's Book page 32. Read and answer.

1 What's Tom wearing? \_\_\_\_\_

2 What time is it? \_\_\_\_\_

3 How many girls can you see? \_\_\_\_\_

2  4.5 Listen and number. Then read and match.

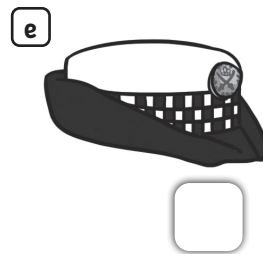
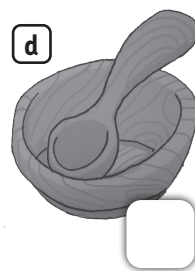
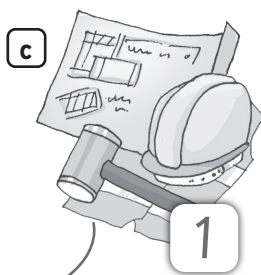
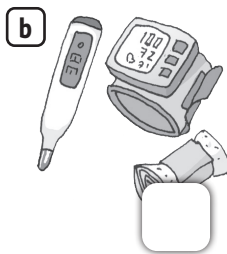
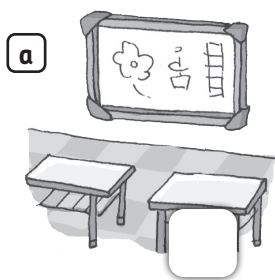

chef

teacher

police officer

nurse

astronaut

builder

firefighter

doctor

artist

pilot

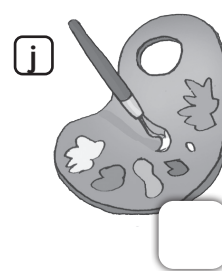
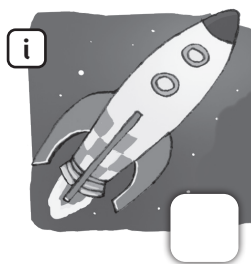
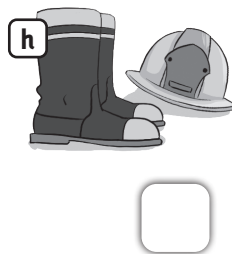
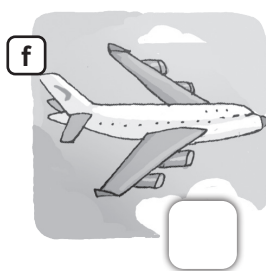

3 Look, read and circle.

1 I want to be a nurse police officer chef.



2 I want to be a/an builder artist doctor.

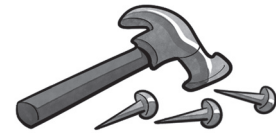

3 I want to be a pilot nurse chef.



4 I want to be a/an builder teacher astronaut.



4 Look, read and write.

doctor pilot ~~teacher~~ artist astronaut nurse

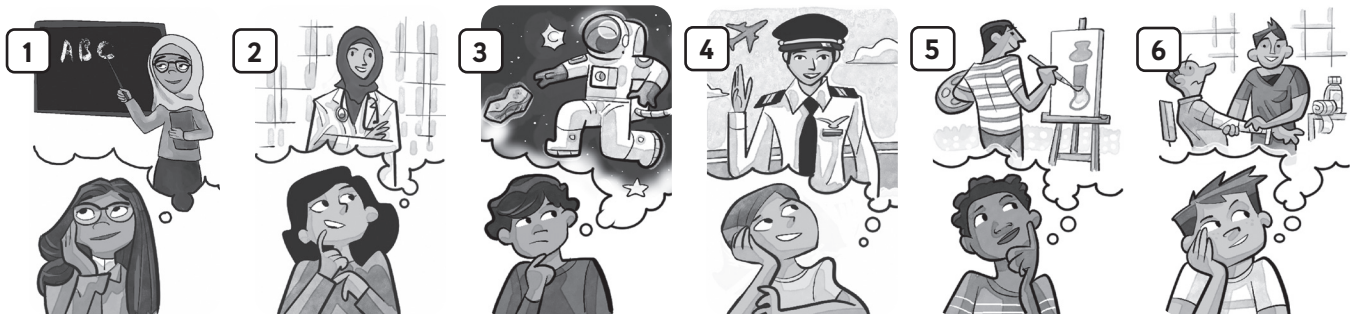

1 I want to be a teacher. 4 \_\_\_\_\_ a \_\_\_\_\_.

2 I want to be a \_\_\_\_\_. 5 \_\_\_\_\_

3 \_\_\_\_\_ an \_\_\_\_\_. 6 \_\_\_\_\_

1 After you read Remember the story. Read and circle.

- |                                   |           |               |
|-----------------------------------|-----------|---------------|
| 1 Laila's ___ is an artist.       | a sister  | b <b>aunt</b> |
| 2 Mr Hani is a ___.               | a chef    | b pilot       |
| 3 Mr Hani ___ the boys and girls. | a teaches | b cooks       |
| 4 Maha goes home by ___.          | a car     | b plane       |
| 5 Bo and Atomic want to be ___.   | a artists | b chefs       |

2 Values Listen and number.

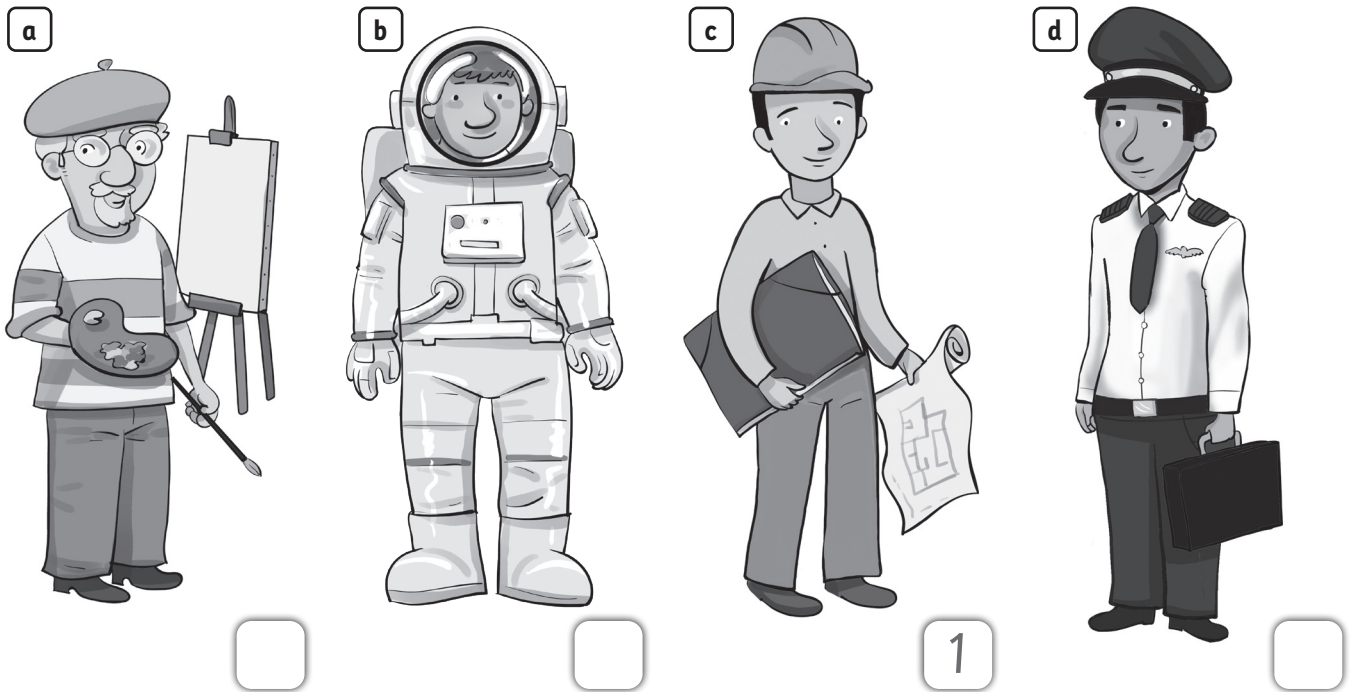

3 Look and colour.



1 Look, read and write.

underground ~~motorbike~~ train car

1	m	o	t	o	r	b	i	k	e
2									
3									
4									

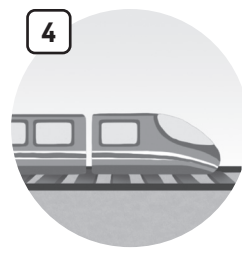
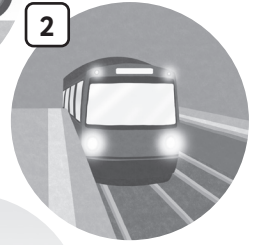
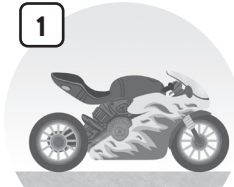

2 Write.

He goes to work by \_\_\_\_\_.

3 Follow, circle and write.

bus boat ~~train~~ car

1 He She goes to work by train.

2 He She goes to work by \_\_\_\_\_.

3 He She goes to work by \_\_\_\_\_.

4 He She goes to work by \_\_\_\_\_.

## 1 Read and circle.

## My family

My family is cool!

My grandpa is a doctor.

He goes to work by car.

My aunt is an artist.

She goes to work by bus.

My brother is a chef.

He goes to work by motorbike.

I love my family!



- 1 My grandpa is **a doctor** **a teacher**.  
He goes to work by **car** **motorbike**.
- 2 My aunt is **an artist** **a pilot**.  
She goes to work by **motorbike** **bus**.
- 3 My brother is **a chef** **an artist**.  
He goes to work by **car** **motorbike**.

2   Write, circle and draw. Then share.

Dear Kareem,

I want to tell you about my job when I'm older.

I want to be **a** **an** \_\_\_\_\_.

My \_\_\_\_\_ is **a** **an** \_\_\_\_\_.

**He** **She** \_\_\_\_\_

by \_\_\_\_\_.

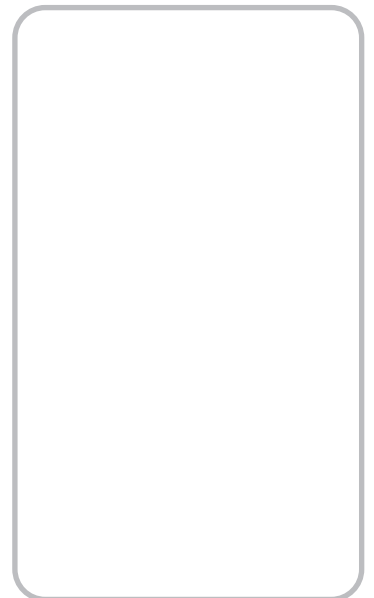

1 Order and write.



ubs reirvd  
b u s d r i v e r

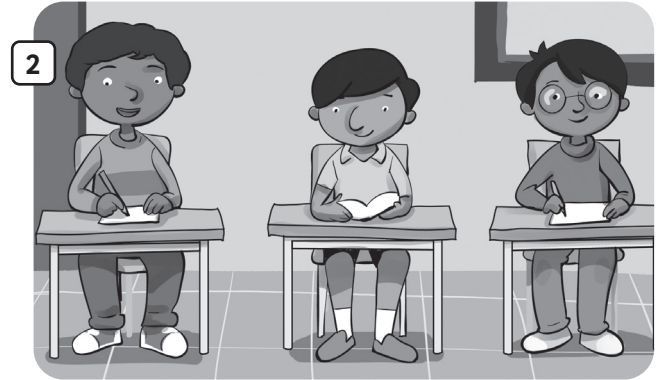

u p l s p i  
\_\_\_\_\_



h l s o c o s b u  
\_\_\_\_\_



p t o s  
\_\_\_\_\_

2 After you read Read and tick (✓).

- 1 Pupils in India don't go to school by school bus.
- 2 Indian school buses are long and short.
- 3 Indian school buses are green.
- 4 Bus drivers drive the school buses.
- 5 Cars and trucks don't stop for school buses.

True False

<input type="checkbox"/>	<input checked="" type="checkbox"/>
<input type="checkbox"/>	<input type="checkbox"/>
<input type="checkbox"/>	<input type="checkbox"/>
<input type="checkbox"/>	<input type="checkbox"/>
<input type="checkbox"/>	<input type="checkbox"/>

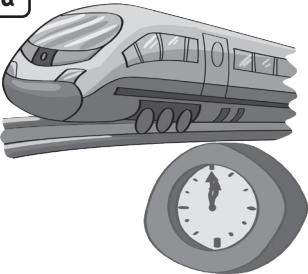
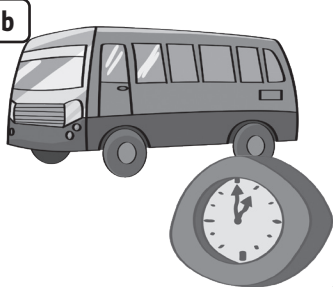
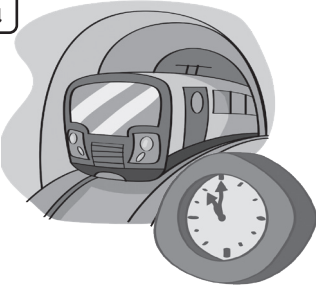
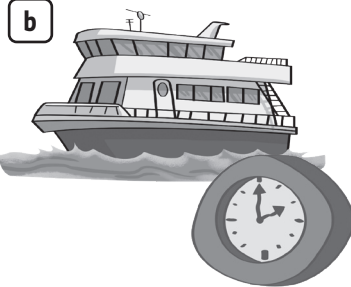
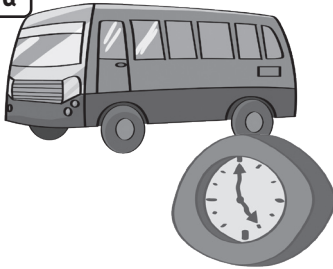
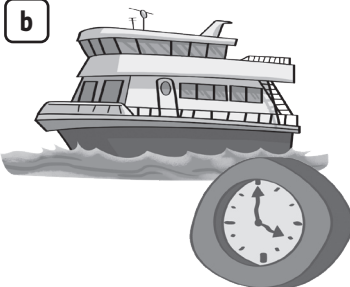

1 4.16 Listen and circle.

<p>1</p> <p>a</p>  <p>b</p> 	<p>2</p> <p>a</p>  <p>b</p> 	<p>3</p> <p>a</p>  <p>b</p> 
---	---	---

Phonics

Lesson 10



1 4.20 Listen and read. Do the questions go up or down?  
Draw an arrow. Then ask and answer with your partner.

What do you want to be?

I want to be a \_\_\_\_\_.

What's your favourite hobby?

My favourite hobby is \_\_\_\_\_.

When do you do homework?

I do homework \_\_\_\_\_.

When do you play?

I play \_\_\_\_\_.

1 Find, circle and write.



doctor



I want to be a / an...

a	r	t	i	s	t	e	a	p	o
g	j	u	f	g	l	e	r	i	a
t	b	u	i	l	d	e	r	l	s
e	y	z	m	c	o	l	n	o	n
a	s	t	r	o	n	a	u	t	t
c	u	y	i	o	k	b	r	e	r
h	c	h	e	f	e	d	s	x	i
e	s	p	o	r	t	s	e	r	s
r	o	m	z	d	o	c	t	o	r



2 Read, draw and share.

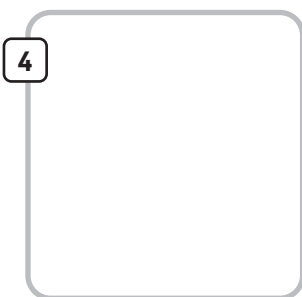
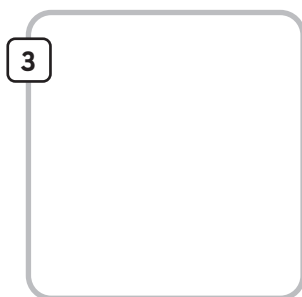
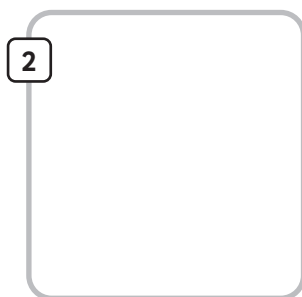
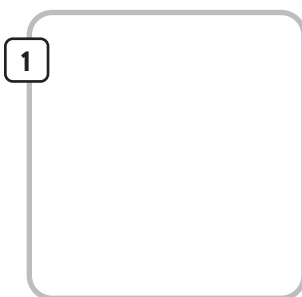

1 He goes to work by boat.

3 She goes to work by car.

2 He goes to work by motorbike.

4 She goes to work by train.



# Language booster

## 1 Look, read and circle.

1

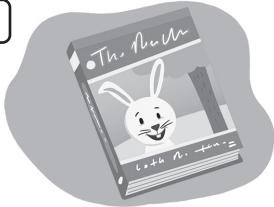

go to sleep

read a book

2



do homework

watch TV

3



play video games

go to bed

4



read a book

go to sleep

5



watch TV

do homework

6



go to bed

play video games

## 2 Read about Fadi. Write *and* or *but*.

1 I watch TV and I do my homework.

2 I read a book \_\_\_\_\_ I don't play video games.

3 I play video games \_\_\_\_\_ I watch TV.

4 I go to bed \_\_\_\_\_ I don't go to sleep.

After school...



**3 Read and order the dialogue.**

- Me, too! Let's play together now!
- I like reading a book. How about you?  
Do you have any hobbies?
- Yes. I like painting.
- 1 What's your favourite hobby?

**4 Complete the dialogue. Use different hobbies.**

- What's your favourite hobby?
- I like \_\_\_\_\_. How about you?  
Do you have any hobbies?
- Yes. I like \_\_\_\_\_.
- Me, too! Let's \_\_\_\_\_ together now!

**5 What are Amina's hobbies? Read and circle.**



Hello. I'm Amina. I've got a lot of hobbies. I like skateboarding and I like playing tennis, too. Oh, and I like playing video games.

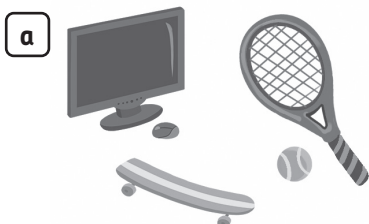

# Months and seasons

## 1 Look, read and write.

September   ~~December~~   August   April

1 December → January → February

2 March → \_\_\_\_\_ → May

3 June → July → \_\_\_\_\_

4 \_\_\_\_\_ → October → November

## 2 Find and circle.



## 3 Listen and read.



My name is Jamal. I like autumn and my favourite month is October. It's sunny in autumn.



## 4 Write, draw and share.

My name is \_\_\_\_\_.  
I like \_\_\_\_\_ and my favourite month is \_\_\_\_\_.  
It's \_\_\_\_\_ in \_\_\_\_\_.



# Independence Day

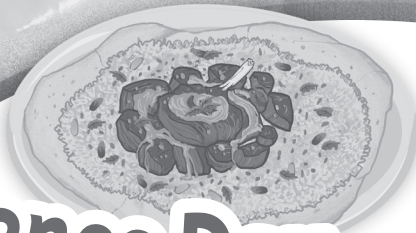

## 1 Look, read and write.

dessert      flag      ~~air show~~  
 fireworks      band      mansaf



air show

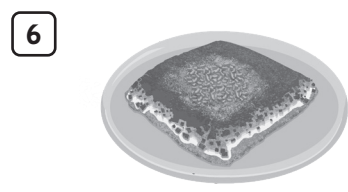
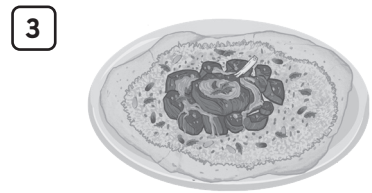

## 2 Read and write.

fireworks      dessert      mansaf  
 flags      ~~parades~~      air show

Independence Day is celebrated in Jordan every year. There are parades.

Children can wave \_\_\_\_\_.  
 In the day you can watch an \_\_\_\_\_.  
 At night, you can watch \_\_\_\_\_.  
 People have \_\_\_\_\_ and eat \_\_\_\_\_  
 for dinner.



# Picture dictionary

sixteen      twenty      seventeen      thirteen      eleven  
fifteen      twelve      nineteen      eighteen      fourteen

**11**

\_\_\_\_\_

**16**

\_\_\_\_\_

**12**

\_\_\_\_\_

**17**

\_\_\_\_\_

**13**

\_\_\_\_\_

**18**

\_\_\_\_\_

**14**

\_\_\_\_\_

**19**

\_\_\_\_\_

**15**

\_\_\_\_\_

**20**

\_\_\_\_\_

# Daily routines and times of the day

1

afternoon    have dinner    morning    do homework  
 go to bed    go to school    play with my friends  
 night    get up    have art lessons    have lunch  
 have breakfast    go home    evening



\_\_\_\_\_



\_\_\_\_\_



\_\_\_\_\_



\_\_\_\_\_



\_\_\_\_\_



\_\_\_\_\_



\_\_\_\_\_



\_\_\_\_\_



\_\_\_\_\_



\_\_\_\_\_



\_\_\_\_\_



\_\_\_\_\_



\_\_\_\_\_



\_\_\_\_\_

glasses      computer      handbag      scarf      sandals  
 baseball cap      trainers      dress      shirt      phone  
 pyjamas      hat      keys      backpack      jeans      socks



\_\_\_\_\_



\_\_\_\_\_



\_\_\_\_\_



\_\_\_\_\_



\_\_\_\_\_



\_\_\_\_\_



\_\_\_\_\_



\_\_\_\_\_



\_\_\_\_\_



\_\_\_\_\_



\_\_\_\_\_



\_\_\_\_\_



\_\_\_\_\_



\_\_\_\_\_



\_\_\_\_\_



\_\_\_\_\_

# Activities and days of the week

3

Tuesday    read books    play basketball    Sunday  
 skateboard    play table tennis    Wednesday  
 play badminton    Thursday    roller skate  
 Saturday    do karate    Monday  
 play video games    Friday    watch TV    play tennis



\_\_\_\_\_



\_\_\_\_\_



\_\_\_\_\_



\_\_\_\_\_



\_\_\_\_\_



\_\_\_\_\_



\_\_\_\_\_



\_\_\_\_\_



\_\_\_\_\_



\_\_\_\_\_

## Days of the week

\_\_\_\_\_  
 \_\_\_\_\_  
 \_\_\_\_\_

\_\_\_\_\_  
 \_\_\_\_\_  
 \_\_\_\_\_

\_\_\_\_\_  
 \_\_\_\_\_  
 \_\_\_\_\_

car                    underground                    doctor                    chef                    artist  
 bus                    nurse                    train                    builder                    police officer  
 boat                    motorbike                    pilot                    teacher  
                                  astronaut                    firefighter



\_\_\_\_\_



\_\_\_\_\_



\_\_\_\_\_



\_\_\_\_\_



\_\_\_\_\_



\_\_\_\_\_



\_\_\_\_\_



\_\_\_\_\_

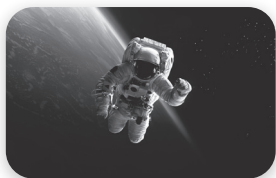

\_\_\_\_\_



\_\_\_\_\_



\_\_\_\_\_



\_\_\_\_\_



\_\_\_\_\_



\_\_\_\_\_



\_\_\_\_\_



\_\_\_\_\_



### **Acknowledgements:**

The publishers would like to thank teachers from schools in Madrid, Spain, Istanbul, Turkey and Ankara, Turkey for their feedback and comments during the development of the materials.

### **Image Credit(s):**

**Alamy Stock Photo:** Imago 48, Kawther Salam 48, Omar Al-Hyari 48, Paul Kingsley 48; **Shutterstock.com:** A Stock Studio 39, algre 47, AlyonaZhitnaya 20, Andrienko Anastasiya 45, AngelinaSchaedler 19, angelo gilardelli 45, antoniodiaz 47, AR PhotosHut 48, Artem Sokolov 46, ASDF\_MEDIA 45, Ayman alakhras 44, bonchan 48, Brett Holmes 41, carballo 44, deesign56 45, diplomedia 47, Dr Ajay Kumar Singh 48, EdBockStock 47, Ermolaev Alexander 44, ESB Professional 47, Evikka 45, F Armstrong Photography 19, Fotokostic 46, GBJSTOCK 47, Gwoeii 47, Gyorgy Barna 46, Hannamariah 40, icemanphotos 48, iprachenko 45, iravgustin 48, Jackson Stock Photography 48, Jovan Barajevac 46, Julija Sulkovska 46, Karkas 45, Khvost 45, kryzhov 44, Latortue 44, LightField Studios 44, Lordn 46, MalikNalik 47, MANTHRI ANUSHA 47, Margo Harrison 48, marslander 45, Maxx-Studio 45, Millenius 48, Monkey Business Images 47, MPH Photos 44, NDAB Creativity 48, niktalena 44, Nina Buday 46, Nomad\_Soul 48, nopparada samrhubsuk 45, NYS 45, Oleg Mikhaylov 46, omardajani 44, Petr Podrouzek 48, pirtuss 19, Pixel-Shot 38, Pozdeyev Vitaly 44, RenataOs 44, Rob Wilson 45, Robert Kneschke 46, 47, rzz 44, sagir 45, Sari ONeal 48, Shelli Jensen 48, Shyamalamuralinath 45, Sklo Studio 46, Skydive Erick 44, Standret 47, Stephen Robertson 19, Suvorov\_Alex 47, Tom Pumphret 19, Tommy Alven 47, Vadim Sadovski 47, Warren Price Photography 48, wavebreakmedia 47, Zeid AbuSaad 48

Illustrated by Mercè Orti Climent (stories), Miguel Calero, Dani Cruz, Javier Monsalvett, José Rubio, José Zazo and Christos Skaltsas (Hyphen)

**Cover Image:** Mercè Orti Climent, Jon Arnold Images Ltd

